



WINSAFE CORP.



GM 120 – CONTAINER TOP LOCK ANCHOR WAND OPERATING INSTRUCTIONS AND MAINTENANCE

	US Patent No. 6834745
	This equipment conforms to EN795:1996
0321	
	

Winsafe Corp.

One Valleywood Drive, Unit # 1

Markham, Ontario – L3R 5L9

Tel: 905-474-9340 Fax: 905-474-9341

Email: info@winsafe.com

www.winsafe.com

Table of Contents

No.	Topic	Page
1	General Specifications	4
2	Description	5
3	Operating Instructions	6
4	Troubleshooting / F.A.Q	9
5	Maintenance / Servicing Procedures	10
6	Cleaning & Lubrication	13
7	Check List	13

WARNING

It shall be the responsibility of all employers and users to read and comply with the following common sense guidelines which are designed to promote safety in the use of the GM120-Container Top Lock Anchor Wand. These guidelines are not all-inclusive nor do they supplant or replace other additional safety and precautionary measures to cover the usual or unusual conditions. If these guidelines conflict in any way with any state, local or federal statute or government regulation, said statute or regulation shall supersede these guidelines and it shall be the responsibility of each employer and user to comply therewith and also to be knowledgeable and understand the pertaining state, local or federal statutes of governmental regulations.

If GM120-Container Top Lock Anchor Wand is resold outside the country of destination the reseller shall provide instructions for use, for maintenance, for periodic examination and for repair in the language of the country in which the product is to be sold.

General

- Do not make any alternations or additions to this equipment without the prior written consent of Winsafe Corp. Any repair shall be carried out in accordance with Winsafe Corp. procedures.
- Serious injury or death can result from improper use of this equipment. Understand all instructions before using them. If in doubt regarding safe use of this equipment consult Winsafe Corp.
- Before using the Anchor Wand, the worker must be trained in the use and application limits of the equipment, proper hookup, anchoring and tie-off techniques, methods of use and proper methods of inspection and storage.

- The Anchor Wands are designed for use on Container (Corner) Casting only. Do not abuse, misuse or use the equipment for purposes or in ways for which it was not intended.
- Anchor Wands subjected to impact loading or fall arrest must be immediately withdrawn from service and sent to Winsafe Corp. for inspection and service.
- The Anchor Wand, Harness and the SRL must be inspected before each use. Any defective components shall be removed from service. Never use any equipment that is damaged or displays excessive wear.
- Check whether the product markings on the Anchor Wand are legible.
- Maintain a Record Card for each Anchor Wand (See Page 14).
- For replacement parts contact Winsafe Corp.

Fall Arrest System: Harness & SRL

- The worker must be secured to the Anchor Wand at all times by a proper Fall Arrest System consisting of a full body harness and a light weight web SRL (self retracting lanyard) with a built in shock absorber.
- The SRL must limit the fall arresting force (M.A.F) to 900 lbs (4 KN) or less.
- Length of the SRL must be carefully selected so that the falling worker cannot contact any lower level stowage, vessel structure etc. in the event of a fall.
- The connectors of the Harness, SRL must be selected to prevent accidental disengagement from each other and the Anchor Wand.
- When in doubt regarding the selection of Harness / SRL; consult Winsafe Corp.

Operation & Use

- Always follow the operating instructions and procedures recommended by the manufacturers of all associated equipment i.e. Harness and SRL.
- Before each use of the Anchor Wand, carefully inspect it according to the Check List (Section 7 – page 13).
- Only 1 worker can be secured to the Anchor Wand.
- Do not use this equipment when in doubt of your fitness to safely absorb shocks from fall arrest. Age and fitness seriously affect the worker ability to withstand falls. Pregnant women or minors must not use the Anchor Wand.
- Anchorage: The Corner Casting must be properly secured to the Container, free from any damage and must be capable of supporting at least 5,000 lbs.

- Avoid movement which may entangle the Life Line onto the Anchor Wand or the worker. Do not allow the Life Line to pass under arms or between legs.
- Swing Falls occur when the Anchorage is not directly above the point where the fall occurs. The total vertical fall distance in a Swing Fall is greater than a direct free fall. Select the length of the SRL so that the falling worker cannot contact any lower level stowage, vessel structure etc. in the event of a fall. The worker should stay within 4 FT or within arms reach of the Anchorage (Anchor Wand) to minimize Swing Falls. Travel beyond 4FT from the Anchor Wand increases the risk of Swing Falls.
- The Employer must have a rescue plan and the ability to rescue the worker in the event of a fall.

Periodic Examination & Maintenance

- The safety of the users depends upon the continued efficiency and durability of the Anchor Wand.
- Due to the complexity and safety critical knowledge required in the dismantling, reassembly or assessment of the Anchor Wand after a fall; periodic examination shall be only conducted by Winsafe Corp. or by a competent person authorized by Winsafe Corp. strictly in accordance with Winsafe Corp. periodic examination procedures.
- Establish a periodic examination schedule conforming to the legislation, frequency of use, and environmental conditions. It is recommended that the periodic examination frequency be at least every 6 months.

1. GENERAL SPECIFICATIONS

- Maximum working load : 350 lbs (158 kg).
- Maximum M.A.F. rating of retractable SRL used is 900 lbs. (4 kn).
- Static load tested to 3648 lbs (16 kn).
- Rotation of Tie-off swivel plate 360°.
- Weight: 5 lbs, (2.3 kg).
- General Construction: Aluminum; Hardware: 18-8 Stainless Steel.
- Finish: Powder coated safety yellow.
- Meets all requirements of fall protection systems in 29 CFR-OSHA 1918.85 (k).
- Conforms to EN795:1996

2. DESCRIPTION

The Top Lock Wand System utilizes an engagement head which secures to the top opening of the corner casting. The engagement head provides a means for securing a retractable lanyard which is connected to the workers safety harness. Anchorage relies on the engagement of the top lock engagement head with the corner casting. This engagement is designed to arrest motion in all directions withstanding resultant pull out force as well as torsional and angular loads.

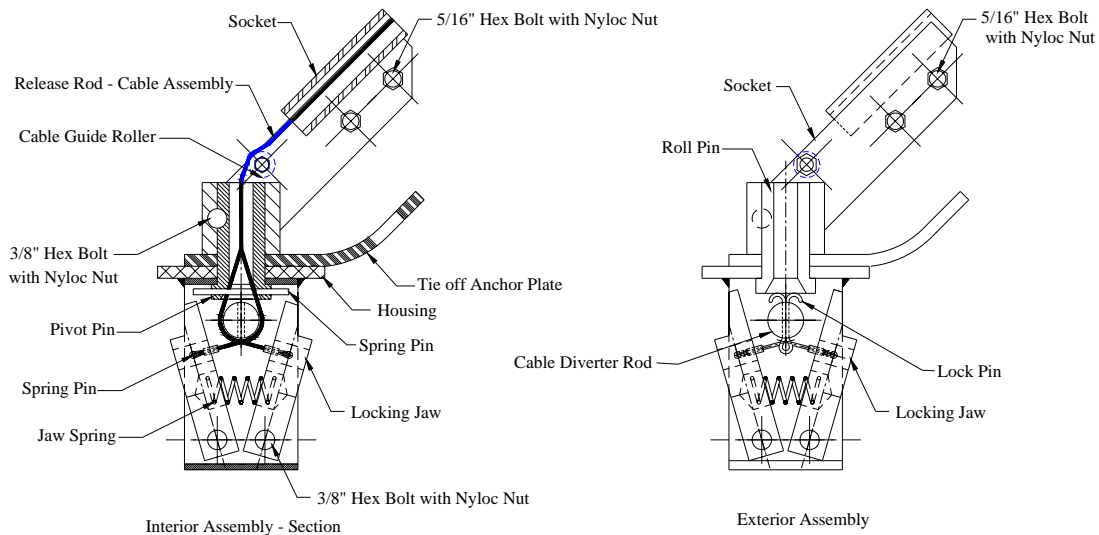
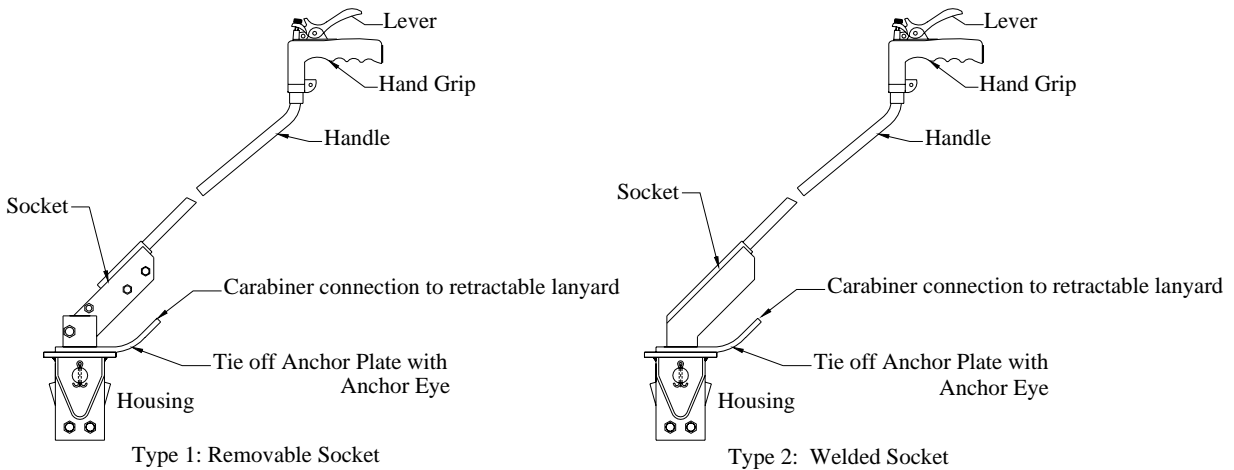

Type 1: Removable Socket

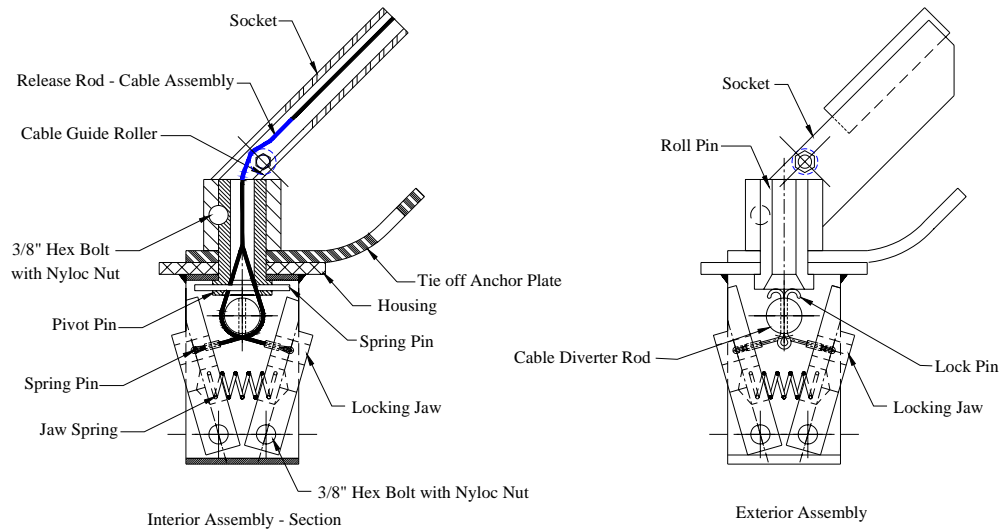

Type 2: Welded Socket

The housing encloses the mechanism i.e. a pair of opposed locking jaws pivotally mounted at the lower end of the housing by pivot pins. The locking jaws are retractable with their upper ends normally extending upwardly and outwardly from the open ends of the housing. The jaws pivot to enter the corner casting and when once engaged they are held apart by a spring. Small cables are attached to each jaw which are in turn attached to the hand lever. A pair of V shaped ribs is mounted on the opposite walls of the housing for guiding the housing into the corner casting. To secure the Top Lock Anchor Wand to the corner casting, the front part of the engagement head is pushed downward into the top cavity of the corner casting so that the projecting ends of the jaws are pressed towards each other until they clear and pivot outward to engage the interior of the corner casting.

3. OPERATING INSTRUCTIONS

When using the anchor wand on top of containers to disengage a stuck twist lock below, the worker shall wear a full body harness and have an approved, self-retracting web lanyard attached between the back D ring of the harness and the anchor eye on the head of the wand. The SRL housing shall be connected at the back D ring of the harness, and the web double lock snap shall be connected to the anchor eye on the head of the wand.



Before approaching the corner casting, the worker shall pull out sufficient web lifeline to enable him to reach out a full arm's length with the wand. The correct method of approaching the corner casting is at a 45 degree angle from the side and leading edges. Before approaching, the worker shall rotate the head of the wand slightly so that the anchor jaws are parallel to the top opening hole of the casting. He shall then approach the corner casting at a 45 degree angle and while reaching out at full arm's length insert the jaws into the casting.

It is recommended to squeeze the release handle partially while inserting the locking jaws into the corner casting. A click sound may be heard as the jaws lock into position. Before the worker approaches further, the wand handle shall be lifted without squeezing the release handle to check that the head is locked into the casting. At no time is the worker to be closer than 3 feet (0.9 meters) from a leading edge unless the wand is engaged.



Once the wand is locked into position, the worker may move to the corner and perform the required task. Upon completion, the worker shall step back and disengage the wand by squeezing the handle and lifting the wand out of the casting.

The GM120 wand may also be used to protect lashers when working on the end of containers, provided a deck casting is available.



When hatch covers are open, the GM120 wand provides protection for workers approaching the opening by again locking into a deck casting. Careful selection of the SRL is necessary to reduce the swing factor, yet allowing sufficient length to perform the work.

CAUTION:

- Always inspect the Anchor Wand before each use to ensure that it is not damaged, worn or otherwise failing to function properly. Do not use this device if in other than full safe operating condition.
- To ensure safety after the Anchor Wand is inserted into the Corner Casting, lift the wand handle without squeezing the release handle to check whether the Locking Jaws are locked into the casting.
- Fasten the retractable safety line onto the tie off anchor plate on the engagement head prior to engagement with the corner casting.
- Store in a dry environment.

4. TROUBLESHOOTING / F.A.Q

Any specific enquiry must be sent to Winsafe Corp. Refer to Section 5 for maintenance / servicing procedures. Items marked (##) are considered factory service repairs requiring the device be returned to Winsafe Corp.

a. Hand grip is loose

Cause	Remedy
Fasteners are not secured	Tighten the fasteners properly
Hand Grip is damaged	Replace GM 520 Hand Grip

b. Socket is loose

Cause	Remedy
Fasteners are not secured	Tighten the fasteners properly
Socket is damaged	Replace GM 297 CLS Handle Socket ----- (##)

c. Locking Jaws do not retract when the lever is operated

Cause	Remedy
Lever of the Hand Grip is broken	Replace GM 520 Hand Grip
Cable adjustment nut is missing / damaged (located on top of the handle)	Replace Cable Adjustment Nut (No. 8 Nyloc Nut)
Cable Guide Roller is damaged	Replace GM332 Cable Guide Roller
Cable is cut / damaged	Replace GM 301 Release Rod Cable Assembly ----- (##)
Spring Pins are bent / broken / missing	Replace 1/8" x 1 1/4" Long Spring Pin for Cables ----- (##)
Locking Jaws require calibration	Calibrate the Jaw movement (see Section 5)
Cable Diverter Rod is bent or broken	Replace GM 300 Cable Diverter Rod ----- (##)

d. Handle does not pivot about the housing

Cause	Remedy
CLS Pivot Pin is worn out	Replace GM 299 – CLS Pivot Pin ----- (##)
Tie Off Plate is interfering with the pivot movement	Check Tie Off Plate for damage. Replace if necessary ----- (##)
Spring Pin on the Pivot is missing or damaged	Replace Spring Pin installed on the Pivot Pin ----- (##)

e. Locking jaws do not push out when the lever is released

Cause	Remedy
Housing obstructs the motion of the Locking Jaw	Check Housing for Damage. Replace GM 296 CLS Housing ----- (##)
Locking Jaws require calibration	Calibrate the Jaw movement (see Section 5)
Jaw Spring is missing or broken	Replace GM 120 Jaw Spring ----- (##)
Cable Diverter Rod is bent / broken / missing	Replace GM 300 Cable Diverter Rod ----- (##) Replace Cotter Pin on Cable Diverter Rod

f. Housing pops out of the corner casting when pulled

Cause	Remedy
Locking Jaws are not engaging properly in the Corner Casting	Jaw Springs may be damaged. Replace GM 120 Jaw Springs ----- (##) Replace GM 298 Locking Jaw (if required) ----- (##)
Housing obstructs the motion of the Locking Jaw	Replace GM 296 CLS Housing ----- (##)
Locking Jaws require calibration	Calibrate the Jaw movement (see Section 5)

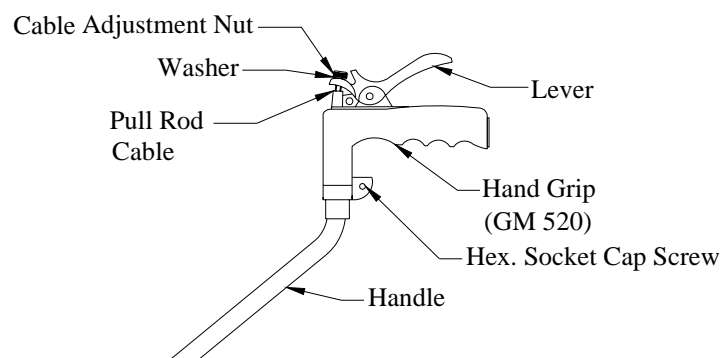
5. MAINTENANCE / SERVICING PROCEDURES**1. Replacement of GM 520 -Hand Grip**

- Unlock the Cable Adjustment Nut & washer to disengage the Cable from the Hand Grip / Lever.
- Disengage the No. 8 Hex Socket Cap Screw & Nyloc Nut. The Cable is now inside the Hand Grip / Handle.
- Pull out the Hand Grip from the Handle.

- d. Pass the Cable through the replacement Hand Grip.
- e. Secure the Cable onto the Hand Grip by installing the Cable Adjustment Nut & washer onto the Lever.
- f. Insert and Secure the Hand Grip to the Handle using No. 8 Hex Cap Screw & Nyloc Nut.
- g. Recalibrate the Locking Jaws (see Section 3).

2. Replacement of GM 332 – Cable Guide Roller

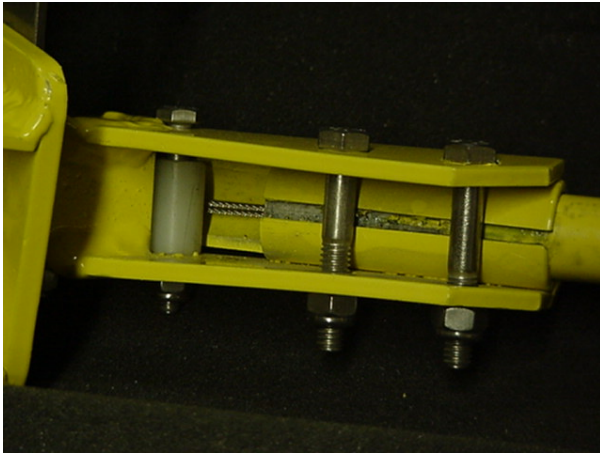

- a. The Cable Guide Roller is installed on the Socket.
- b. Disengage the Cable Guide Roller from the Socket by removing the 5/16" Hex Bolt & Nyloc Nut.
- c. Place the replacement GM 332 Cable Guide Roller between the side plates of the Socket. The Cable must be on top of the Roller as shown.
- d. Replace 5/16" Hex Bolt & Nyloc Nut.

3. Calibration of the Locking Jaw

Important Notes:

- a. The Locking Jaws are calibrated by:
 - ✓ Operating the Cable Adjustment Nut on the Hand Grip.
 - ✓ Relocating the Hand Grip on the Handle (1/4" maximum).
- b. Clockwise rotation of the Cable Adjustment Nut pulls the Locking Jaws further into the Housing.
- c. Anti-clockwise rotation of the Cable Adjustment Nut allows the Locking Jaws to project further out of the Housing.
- d. Relocation of the Hand Grip away from the Handle pulls the Locking Jaws further into the Housing.
- e. Relocation of the Hand Grip towards the Handle allows the Locking Jaws to project out of the Housing.
- f. The Hand Grip must have a minimum of 3/4" engagement on the Handle and must be properly secured.
- g. Before you calibrate, insure that the Jaw Springs, Cable Diverter Rod & Cable Guide Roller are working and free from any damage.

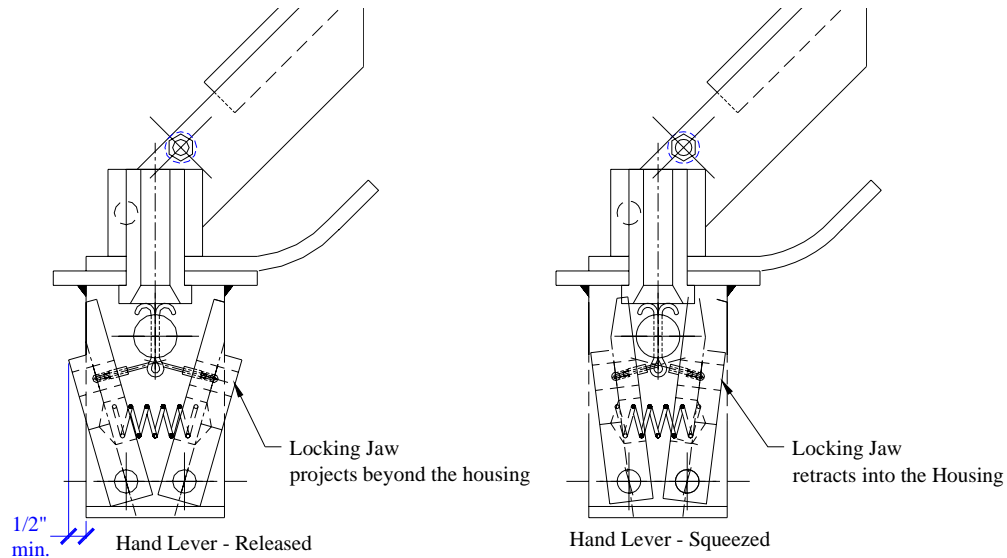

Procedure:

- Squeeze and Release the Hand Lever.
- The Locking Jaws should project beyond the housing as shown above.
- If the Jaws do not extend sufficiently or extend too far, reset the Cable Adjustment Nut or Relocate the Hand Grip as required.

Note: When adjusting the Cable Adjustment Nut it will be necessary to use a pair of vice grips to hold the pull rod while the nut is being turned.

- For optimum clamping, the Locking Jaws must project beyond the housing so that the full jaw step protrudes.

Note: Squeeze the Hand Lever. Check whether the Locking Jaws retract completely into the Housing.

6. CLEANING & LUBRICATION

- ✓ The Anchor Wand will function better and last longer if its kept clean and well lubricated
- ✓ Wash down the Anchor Wand with fresh water every week. When dry, spray WD40 lubricant or equivalent at:
 - all pivot points.
 - all joints.
 - the location where wire rope runs over the guide roller.
 - the Locking Jaws.
- ✓ Do not force dry with heat.

7. CHECKLIST

It is the responsibility of the user / operator of this equipment to inspect all components of the Anchor Wand before each use. Never use the Anchor Wand if it's damaged or displays excessive wear. Any questions regarding operation, maintenance or loading conditions contact Winsafe Corp.

Before Each Use

- ✓ Proper Fall Arrest System components are required using a full body harness and shock absorbing web SRL (self retracting lanyard) with a maximum arrest force (M.A.F) of 900 lbs or lower.
- ✓ Inspect all welds on the Anchor Wand for cracks.
- ✓ Check whether all fasteners are secured properly.
- ✓ Inspect whether the Hand Grip is secured and functioning properly.
- ✓ Check the Locking Jaws to verify that they extend properly and retract fully when the Lever (Hand Grip) is squeezed.
- ✓ Check whether the Tie off Anchor Plate is free from damage (bent down from original position).
- ✓ Rotate the Housing to insure Roll Pin allows a maximum of 90 degree handle rotation.

RECORD CARD

PRODUCT **GM120 - CONTAINER TOP LOCK ANCHOR WAND**
MANUFACTURER WINSAFE CORP
 ONE VALLEYWOOD DR. UNIT #1
 MARKHAM, ON, CANADA

SERIAL / BATCH # :

YEAR OF MANUFACTURE :

DATE OF PURCHASE :

DATE FIRST PUT INTO SERVICE :

PERIODIC EXAMINATION AND REPAIR HISTORY

Date	Reason for Entry (Examination or repair)	Defects noted, Repair carried out	Signature of competent person	Next due date for Periodic Examination